

Specification of an operator for the design of architectural forms: “Pleating”

Jean-Paul Wetzel¹, Salim Belblidia² et Jean-Claude Bignon²

MAP CRAI UMR n°694/CNRS/CULTURE,

¹Architecture School of Strasbourg,

² Architecture School of Nancy,

<http://www.crai.archi.fr>

Abstract. During the creative phase, the architect introduces hypotheses and validates them by trying out various adjustments during the process of conception. The use of existing CAD tools during the conception phase is not compatible with the iterative aspect of this process. So the challenge is to define a model that takes into account the entire creative process in a trial and error framework during the conceptual phase. In this article we will define the “pleating” operator.

Keywords. Morphological operation, pleating, folding, operator.

Introduction

An increasing number of architects are using the capabilities of three-dimensional modellers to shape new forms. However, working with these shapes, particularly their realization, quite often demands adjustments not compatible with a linear approach to modelization such as those practiced by classical geometrical modellers (autocad, archicad, allplan...).

From a cognitive point of view, design is a “speculative” and exploratory activity (Rowe 1987; Estevez 2001; Borillo et al. 2002) that establishes through various means of expression the representations of one or several mental images of the project. These representations are fragments of the creative process and work as a rich heuristic ensemble (Zeisel 1984; Rowe 1987). They represent the numerous intermediate steps which help the designer to clarify his thoughts, simulate solutions, reduce his uncertainties (Lebahar 1983) and so choose among his ideas. This is why it is important that tools which assist in creativity must constitute part of an iterative and parametric process.

In this article we assume that during the creative phase of a project the genesis of shapes results from successive operations of transformation which are based on semantic objectives and guided by figurative pictures. The designer moves from source-forms to ones which are compatible with what is being conceived. Progress only results from many trials and major redefinitions of the objects' shapes. These variations can be produced either directly by the designer or by using one of the designer's generative algorithms.

We assume that these transformations can be generated by parametric morpho-semantic operators.

Morpho-semantic operators

Morpho-semantic operations are those shape modifications that are inspired by teleological models, imported to various fields: nature, mechanics, art... Architects use these operators with a reference in mind (wrinkled – like a sheet of paper or twisted – like chewing-gum).

Morpho-semantic operations are usually combinations of several geometric operations and have a set of parameters (axis, angle, bearing ...) used to produce various outcomes.

In order to identify these operations we have analyzed a corpus of buildings from among the “non-standard architecture” to see how forms can vary in different stages during the sketching phase in the hands of different architects. From an analysis of these variations, we could modelize several operators so that they become reproducible. In this manner we have modelized the “fold”, “twist”, “bulge”, “grow” operators.

In the following section of this article we will focus on the “pleat” operator, a function widely used in our profession.

The « pleating » operator

In order to define the “pleating” operator we will start with an inventory of the various functions which can describe this action in existing modellers. We will then work on an analysis that shows up morphology based on pleating actions in non-standard architecture. We will focus on three buildings in particular: the Year 2000 Church by Peter Eisenman, the Berlin Jewish Museum by Daniel Libeskind, and the Cornell School of Architecture by Morphosis. The aim of this study is to specify this operator to adapt it to the architectural domain.



Figure 1. Examples.

The existing specification

In classical geometry-oriented modelling (3DS max, Maya...), the “pleat” function applies to a volume 3D and is approximated by a sinusoid with the following parameters: period, number of periods, fold amplitude. These parameters permit only the realization of a succession of regular folds that are insufficient for objects one aims to generate.

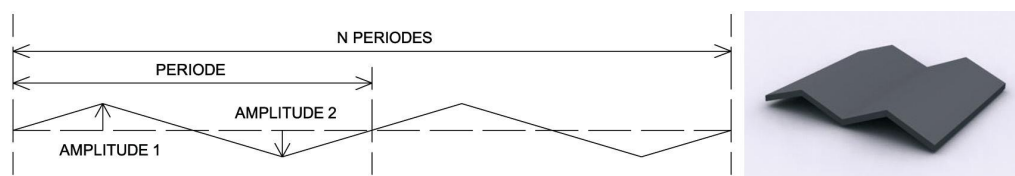

Figure 2. Parameters of a “Pleating” function in a traditional modeller.

Cases study

Our analysis starts with a detailed examination in order to demonstrate the link between the various parameters that can be referred to by architects and the shapes that can thus be obtained.

Peter Eisenman in his Year 2000 Church project (Figure 3) defines the place of worship as an intermediary between the pilgrim and God. He formalises this idea making reference to the formation of a crystal at the molecular scale.

The pleating operation identified on the geometry of his church shows only minor distortions, thus creating an almost regular pattern. As for the angular values of the pleats, we observe that they are regular on the first two pleats but attenuated on the last one.

In this example, we have observed that fold n°3 is the one with the greatest distortion on the two parameters of “distance” and “angular values”, when compared with the other pleats. We can thus conclude that the distortion of a pleating operation would work on the angular values as well as on placement of the pleats, and in cases like this one they can be linked together.

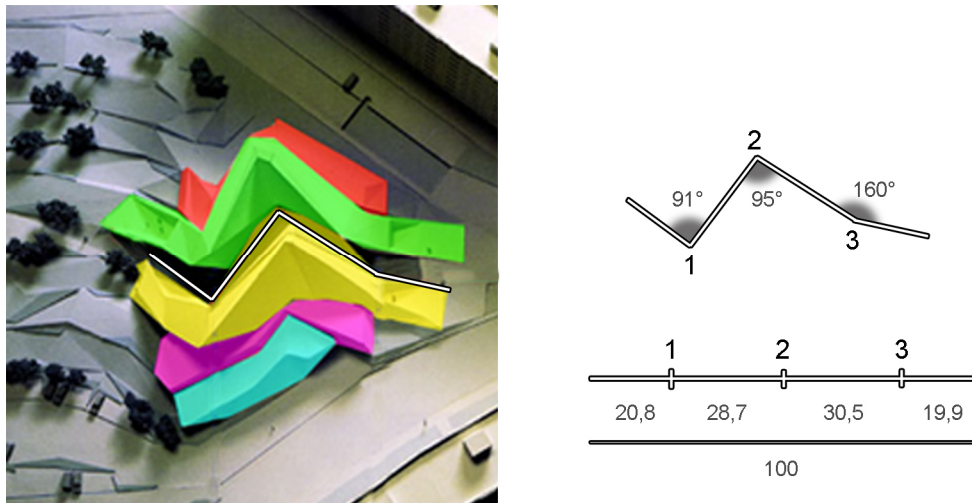

Figure 3. Year 2000 Church project, Peter Eisenman.

In the extension of the Berlin Jewish Museum (Figure 4), Daniel Libeskind’s purpose was to formalise a flash of lightning. The semantic field of the “zigzag” is developed as much on the ground plan as on the façade. In our analysis, we will detail more particularly the way the pleat operation was treated and transcribed on to the plan.

At first glance, the global volume of the building does not result from an operation of regular pleats. Indeed the pleats are implanted in a very irregular manner on the whole structure and their angular values are very erratic. Fold n°4 with a 247° value creates a sort of “break” in the process. One can also see that the geometric beginning and the end are practically at the same height, which could induce limits in relation to the site. These limits could also be expressed through more global parameters regarding the maximum size of the form.

One can also see that the geometric beginning and the end are practically at the same height, which could induce limits in relation to the site. These limits could also be expressed through more global parameters regarding the maximum size of the form.

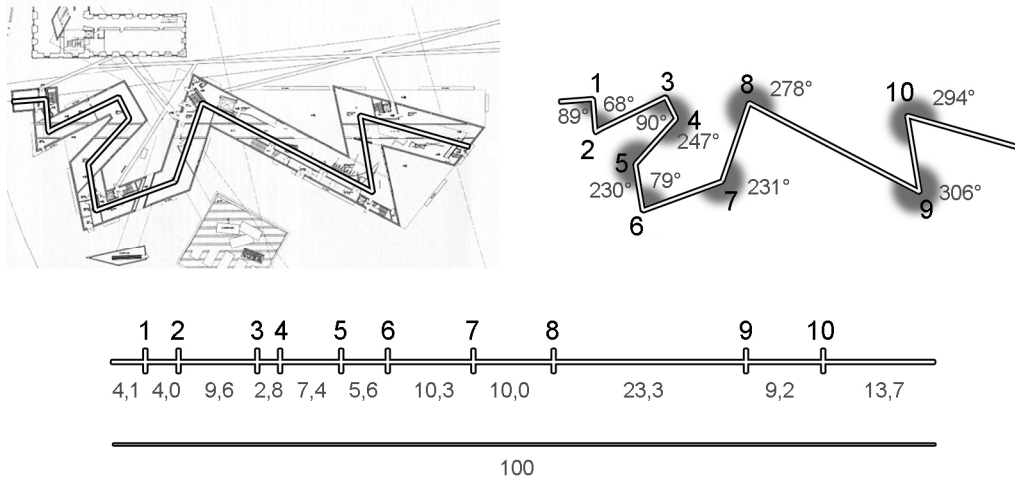

Figure 4. The Berlin Jewish Museum, Daniel Libeskind.

A dented roof covers the central part of Morphosis's Cornell School of Architecture. The pleats inducing this deformation are practically all implanted in a regular manner. But pleat n°6 is located nearer to the preceding deformation than the others, and pleat n°1 is situated further than the others from the edge of the geometry. As this reoccurs in all the analysed examples, it implies that there are parameters of implantation on the deformation on the form.

The pleat value is not regular and allows the roof to be roughly shaped as an "arc". This formalisation is due to the fact that all antagonistic pleats are greater than the preceding ones. This implies that there are distinctive schemes of distortion that create different families of form.

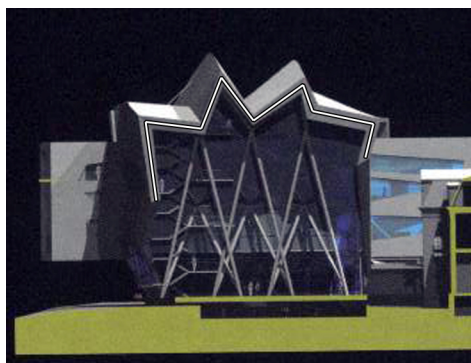

Figure 5. Cornell University School Of Architecture, Morphosis.

The analysis of these three works has allowed us to uncover several teleological models, such as "zigzag" form or "crystal" form which can guide pleating operations, like several parameters characterizing the concept of "pleating".

Specification

Pattern

In order to characterise our "pleating" operator, we propose to model it as a succession of antagonistic folding operations, using the "folding" operator already specified in a preceding work (Wetzel et al. 2006). The operator "pleating" $P()$ is composed by

several operator “folding” $F()$ and several variables are necessary to unfold it: the form to be pleat (f), the number of folds (n), the angular value of each fold (a_n), the distance between each fold (d_n) and plan (p) of reference.

$$P(f) = f \cdot F(p, a_1, d_1) + f \cdot F(p, a_2, d_1 + d_2) + \dots + f \cdot F(p, a_n, d_1 + d_2 + \dots + d_n)$$

Interface and instrumentation

The operator “pleating” can be used to generate a regular pleating, in this case the user specifies only the number of folds (n) and their values angular (a). These folds are distributed in a regular way along the reference plan of the object to be pleated. (figure 6).

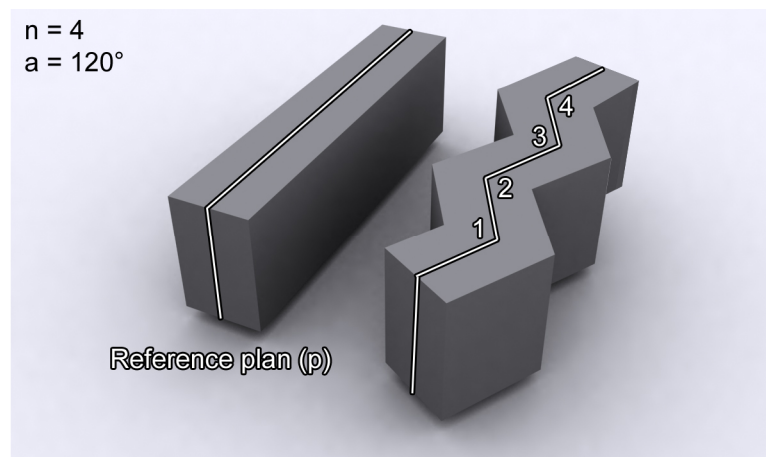

Figure 6. Example of a regular “pleating” operation.

In the previous part, noted that it could exist irregularities in the operation of “pleating”. We have pointed out two types of distortions in the pleating process. The first one acts on the angular value of the folds and the other acts on the implantation of the folding operations on the form. These distortions can linked or not with one another to obtain diverse variations. In this manner some more general limits to the form can be realized.

These distortions can thereby be controlled through changes in the parameters or through a generative process guided by the user to permit converge towards an acceptable solution and one that conforms to the model implied.

The addition of new distortions in a pleating operation implies the variation of each fold. Thus, functions which permit the obtainment of random distortions may be implemented.

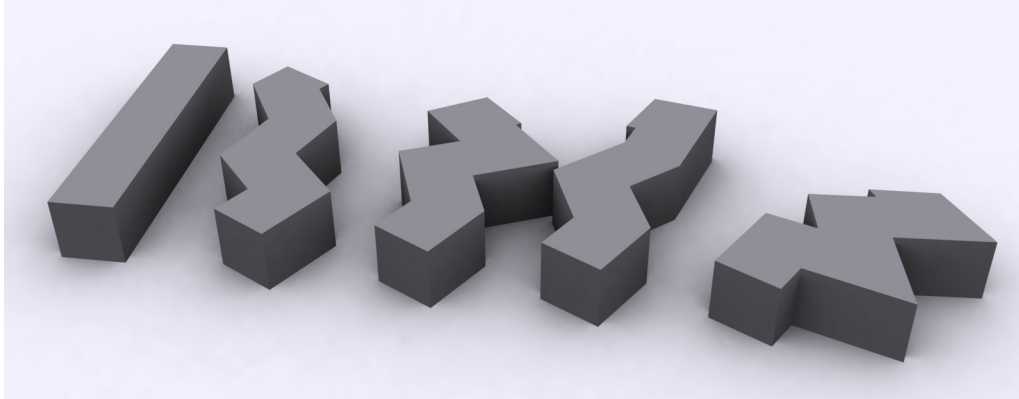

Figure 7. Examples of random variations of the “pleating” operation.

The user will call upon a regular operation initially in order to place the folds on the geometry then will disunite the variables in order to adjust them with one directly on the model. In order to finely adjust the pleating, the user should be able to adjust parameters a_1 to a_n and d_1 to d_n directly on the model. A touch screen would be, in our opinion, the most ergonomic tool as this would allow the user to interact directly with the 3D model.

We have identified two types of distortions which can be expressed as a percentage. The expression of these variations would necessitate a button permitting the generation of solutions. It uses two parameters representing the maximum variation tolerated for the two types of identified distortions (angular and of establishment).

In order to check the specifications of this operator, we currently produce a prototype programmed in the form of one plug-in for 3D studio max, the application of the called upon parameters will allow to validate or not the coherence of our step.

Conclusion

In this article we have demonstrated the pertinence of the concept of morpho-semantic operations associated with motor to generate variations to account for operations implicating transformation of forms during architectural creation. We have more specifically focussed on the “pleating” operator based on the analysis of three buildings belonging to “non standard” architectural works.

In parallel with this modelling, we are presently working on a formal research approach, based on a real case, in order to draft a conceptual appropriate to the project. Our work is also directed towards the search for an interface making it possible to interact by using gestures

The follow up to this work will be to study a more advanced modelling of the conceptual framework and all morphological operators with a view to conceiving 3D modelling environment permitting new morphological expressions.

References

Borillo, M. and J.-P. Goulette: 2002, Cognition et création, Explorations cognitives des processus de conception, Sprimont, Mardaga.

- Estevez, D.: 2001, Dessin d'architecture et infographie. L'évolution contemporaine des pratiques graphiques. , Paris, CNRS Editions.
- Lebahar, J.-C.: 1983, Le dessin d'architecte - simulation graphique et réduction d'incertitude., Marseille, Editions Parenthèses.
- Rowe, P. G.: 1987, Design Thinking, Cambridge, The MIT Press.
- Wetzel, J.-P., S. Belblidia and J.-C. Bignon: 2006, A Study for Parametric Morpho-Semantic Operators to Assist Architectural Conception at the Drafting Stage, CGIV06 / International Conference / 3rd Computer Graphics, Imaging and Visualisation Sydney, Australia: 8.
- Zeisel, J.: 1984, Inquiry by Design: Tools for Environment-Behaviour Research, Cambridge, Cambridge University Press.